

RESOLUTION NO. 2023-08-03

A Resolution of the Board of Commissioners of Southwest Suburban Sewer District, King County Washington, confirming action taken by the District in the Execution of Developer Extensions.

WHEREAS, the District, has approved and authorized execution of Developer Extension Agreements; and

WHEREAS, the Board of Commissioners confirms by resolution its action taken in authorizing the General Manager to enter into contract with Highline Public School District, owner of Evergreen High School Developer Extension and to carry out the terms and conditions of the contract.

NOW, THEREFORE, BE IT RESOLVED, by the Board of Commissioners of Southwest Suburban Sewer District, King County, Washington as follows:

1. The action taken by the Board of Commissioners in authorizing the execution of the aforementioned Developer Extension as set forth herein and as reflected in the minutes of the District's regular meeting, are hereby confirmed.

2. The District's General Manager is authorized to fully implement this agreement and to enforce the terms and conditions of the contract.

ADOPTED by the Board of Commissioners of the Southwest Suburban Sewer District, King County, Washington at a regular meeting held on this 1st Day of August 2023.

SOUTHWEST SUBURBAN SEWER DISTRICT
KING COUNTY, WASHINGTON

Individual Commissioner's
Vote on Resolution

In Favor of: _____
Opposed: _____
Abstained: _____



Scott Hilsen,
President and Commissioner

In Favor of: _____
Opposed: _____
Abstained: _____



William Tracy,
Vice-President and Commissioner

In Favor of: _____
Opposed: _____
Abstained: _____



Susan M. Genzale
Secretary and Commissioner

CERTIFICATE

I, Susan Genzale, Secretary of the Board of Commissioners of Southwest Suburban Sewer District, King County, Washington, DO HEREBY CERTIFY that the foregoing resolution is a true and correct copy of Resolution 2023-08-03 of said Board, duly adopted at a regular meeting thereof held on the 1st day of August, 2023, signed by the members of such Board in attendance at such meeting and attested by myself in authentication of such adoption.

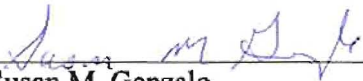

Susan M. Genzale
Secretary of the Board of Commissioners
Southwest Suburban Sewer District



Capital Planning and Construction Department

Ellie Daneshnia, Executive Director

17810 8th Avenue South, Bldg. A

Burien, WA 98148

Office: 206-631-7500

April 6, 2023

Board of Commissioners
Southwest Suburban Sewer District
Attention: Mr. Ritch Schule
17840 Des Moines Memorial Dr S,
Burien, WA 98148

RE: Evergreen High School Developer Extension Agreement

Dear Board of Commissioners:

The Highline School District, as the developer/ owner of the new of Evergreen High School, hereby requests a waiver for the requirement to provide a performance and maintenance bond that is normally required by Southwest Suburban Sewer District as part of the developer extension agreement. The Highline School District is a municipal corporation with an elected Board, and as such may be exempt from posting bonds under RCW 35A.21.250. By granting this exemption the following sections are no longer applicable to the agreement:

- Section II. Developer part (g) and (h)
- Section III. Plan part (e)
- Section VIII Performance part (a) thru (c)
- Section XII. Payback Agreement Execution and Recording part (a) thru (h)

Cornerstone General Contractors (Cornerstone) is the School District's General Contractor/Construction Manager (GC/CM). Cornerstone is one of the largest General Contractors in the Northwest. As noted in section VI. Evidence of insurance, Cornerstone will provide the required certificate of insurance to the Sewer District.

Sincerely,

A handwritten signature in black ink, appearing to read "Ellie Daneshnia", written over a white background.

Ellie Daneshnia
Executive Director
Capital Planning and Construction

FORM E

DEVELOPER EXTENSION AGREEMENT

SOUTHWEST SUBURBAN SEWER DISTRICT, hereinafter referred to as "District," and Highline Public Schools, hereinafter referred to as "Developer" enter into the following agreement, hereinafter referred to as "Contract," and make the following mutual promises and covenants as consideration for the District providing a sewer connection to the proposed developer extension and the Developer constructing the proposed developer extension pursuant to the terms and conditions of the Contract and agreeing to convey and transfer the improvements to the District pursuant to the terms and conditions of this Contract upon completion of the developer extension. The proposed extension of the sanitary sewers will be installed in the road, easements and/or other approved rights-of-way and shall be for the use and benefit of the property legally described as follows:

The parties, in consideration of the following expressed mutual covenants and promises, agree, promise and covenant as follows:

I. DISTRICT

The District promises, covenants and agrees to the following terms and conditions:

(a) The District and/or its representative shall periodically inspect the developer extension, while under construction, to verify that the developer extension complies with the design standards and construction specifications of the District; and conforms with the present rules, regulations and resolutions of the District and conforms to the terms of said Contract. Such inspection shall in no way relieve the Developer of its responsibility for compliance with the terms of the Contract and Contract

specifications as well as the rules and regulations as imposed by the County or other agencies.

(b) The District agrees to allow the developer to make the connection to the present sewer system of the District upon the completion of the developer extension by the Developer upon its fulfillment of the terms and conditions of the Contract, and when the Developer has delivered to the District a bill of sale, obtained the necessary permits and easements, and the extension has been approved by the consultants, and accepted by the Board of Commissioners. The action of the District shall be formalized by resolution passed by the Board of Commissioners authorizing the District, through its staff, to make the connection between the developer extension and the District's sewer system.

(c) Connection of the extension by the District shall not relieve the Developer of the obligations to correct defects in labor and/or materials as heretofore provided and/or the obligations set forth in the applicable paragraphs hereto. The connections of the extension authorized by the District's Board of Commissioners shall cause said extension to be subject to the control, use and operation of the District, which shall be subject to all regulations and conditions of service.

II. DEVELOPER

(a) The Developer agrees to comply with the District's current "Standard Specifications Manual", as referenced in the District's Developer Extension Manual, as may be updated from time to time.

(b) The Developer agrees to comply with all environmental requirements as set forth either by the District or by appropriate city, county, state or federal agencies. Developer agrees to prepare an environmental checklist or environmental impact statement at its sole expense, if so directed by applicable lead agencies as set forth in SEPA and applicable administrative regulations and laws of Washington. For extensions outside of the District boundaries but within the potential service areas included in the Comprehensive Plan, Developer shall obtain the necessary approval from the Boundary Review Board and other necessary agencies.

(c) If the District's consultants are to prepare the plan for the developer extension, the Developer will deposit with the District a certified check for the District's administrative, engineering design and inspection and allied fees simultaneously with the execution of this Contract pursuant to the project cost estimate as prepared by the District and incorporated herein as Exhibit A.

(d) The plan for the developer extension shall be in accordance with the State of Washington, Department of Ecology's criteria for sewage works design.

(e) If the Developer selects his own engineer to prepare the plan, the plan must be signed by a professional engineer registered in the State of Washington. The Developer will deposit with the District a certified check for the District's administrative,

engineering review and inspection and allied fees simultaneously with the execution of this Contract pursuant to the project cost estimate as prepared by the District and incorporated herein as Exhibit A.

(f) Prior to the connection of the facility, the Developer shall sign a Bill of Sale, and actual time and expense charges shall be determined and fees and costs shall be adjusted to provide for a refund by the District or additional payment by the Developer. If additional payment is required, the Developer shall make such payment to the District prior to the connection of the extension to the District's system.

(g) The Developer shall prior to authorization to begin construction, submit a Performance and Maintenance Bond in accordance with the provisions of Section VIII of this Contract. This Performance and Maintenance Bond shall be held by the District until final inspection and approval by the District one year after the project has been accepted by the District. This Performance and Maintenance Bond shall: ED

(1) Insure strict compliance with the District's standards, specifications and conditions.

(2) Insure the District against any damage to its existing system or the proposed extension as a result of the Developer's failure to properly perform under this agreement.

(3) Provide for reimbursement to the District for any and all necessary repairs or restoration of other properties if the Developer does not do so within 24 hours after notice from the District.

(h) The Developer further simultaneously with the execution of this Contract shall pay to the District any latecomer charges, or connection charges (~~and~~ ^{ED} facilities or local facilities charges) as they may pertain to the subject real property of the developer extension.

III. PLAN

(a) The Developer will submit a plan to the District which contains all necessary information required for the construction of the proposed improvements which comply with the District's current Design and Construction Standards, and shall be updated and revised as necessary to indicate further development showing all utilities, roads and drainage facilities. Complete architectural plans shall be submitted if requested. The Developer further agrees to furnish copies of final plat and/or surveys.

(b) The plan shall be submitted in reproducible form, the scale of which shall be one inch equals fifty feet. The plan shall be on twenty-two inch by thirty-four inch mylar. The plans shall be prepared using AutoCAD, and an electronic copy of the plans shall also be submitted.

(c) The plan shall be submitted to the District within sixty (60) days following the execution of the Contract. The plan shall be reviewed by the District and the Developer shall be advised within ten (10) working days after the next regularly scheduled Board of Commissioners meeting regarding its acceptance or rejection. If the District does reject the plan, the District shall so specify its exceptions to the plan. The Developer shall have the right to submit the plan to the full Board and be present at the hearing. Said hearing shall be held within twenty (20) days, upon written request by the Developer. The Developer or its agent may be present at the hearing to present its plan and shall explain to the Board the exceptions or justifications for the exceptions. The Board shall make a decision either approving the action taken by the District in rejecting the plan, accepting the plan subject to exceptions, specifying to the Developer the exceptions to be corrected to comply with the District's requirements and so indicate its approval of the plan upon conditions being fulfilled. The Board's decision shall be final.

(d) If the plan is not accepted and the Developer does not desire to continue with the developer extension, any administration fees paid to the District or fees paid to the District and not earned for administration and allied costs shall be refunded to the Developer. The District shall be compensated for its services rendered and any cash security deposit shall be refunded to the Developer.

(e) Following the acceptance of the plan by the District and receipt by the District of a certificate of insurance complying with the insurance requirements as set forth herein and the execution and ~~submittal of a performance bond~~, the Developer may begin construction and the cut sheet(s) shall be given to the Developer by the District's engineer. No cut sheet(s) shall be given to the Developer or to the Developer's contractor until the Developer has complied with these requirements and the execution and submittal of a performance bond and a pre-construction conference held with all items covered and/or complied with on the "Pre-construction Conference Review". The Developer may begin construction five (5) days after the pre-construction conference. EP

(f) All construction performed by and for the Developer will be in compliance with the District's current Standard Specifications Manual, as referenced in the Developer Extension Manual. The Developer shall have the responsibility to secure and become familiar with these Standard Specifications.

(g) The Developer agrees that there shall be no sewage flow through any mains or facilities constructed by the Developer prior to the connection and approval of the extension by the District.

(h) The Developer shall create all roads to the design sub-grade elevation prior to the start of construction and shall advise the District in writing of any changes which may be contemplated during construction. If the Developer changes the sub-grade elevation of the road after completion of the extension, or any part thereof, the Developer shall be responsible for all costs incurred as a result of such changes in sub-grade elevation. This obligation shall remain in full force until King County or such other

appropriate municipality releases the right-of-way or road construction bond or bond of other descriptions in connection with the Developer's obligation for completion of the road within the area.

(l) If gravity service is not available and a pump facility is required, the Developer shall execute a pump facility agreement in the form provided by the District. All requirements under this Pump Agreement shall be subject to the terms and conditions of this Contract and shall be incorporated by reference into this Contract as if it had been set forth fully herein.

IV. THE CONSTRUCTION CONTRACT

(a) The Developer shall select the Contractor to perform the work described in Part III above. The Contractor shall be submitted to the District for approval and approval will not be unreasonably withheld.

(b) The cost as provided for by the plan as accepted shall be submitted to the District for approval, together with the contract between the Contractor and the Developer and will not be unreasonably withheld.

(c) The Developer may approve any change order, without District approval, so long as the total cost of the project, after adding for the change order, does not exceed 110 percent of the cost approved by the District in Paragraph (b) above. Any change order which causes the cost of the project to exceed 110 percent of the cost approved by the District in Paragraph (b) above must be submitted to and approved by the District and approval will not be unreasonably withheld.

(d) Any change order which is required by the provisions of Paragraph (c) above to be approved by the District, which is not approved by the District, shall not be included in any Bill of Sale conveying ownership of the project from the Developer to the District.

V. ADDITIONAL FEES

An additional fee shall be paid to the District by the Developer for the following additional work, if performed:

(a) Revisions of the Contract plans and specifications and work occasioned by an act of the Developer relating thereto.

(b) Obstruction, delay or prevention of construction staking, replacement of stakes and additional staking.

(c) Additional inspections (City, County, State, others)

(d) Reinspection of deficient work.

(e) Any permit or franchise acquired by the District.

(f) Acts by the Developer which necessitate the District's Manager, staff or consultants to spend extraordinary time on the developer extension, the costs shall be billed accordingly to the Developer. This fee shall be based on the actual time expended by the District or its consultant and be paid by the Developer upon receipt of an invoice from the District. Payment shall be a prerequisite for obtaining connection to the developer extension and sewer service.

VI. EVIDENCE OF INSURANCE

(a) The Developer and its contractor shall assume responsibility for securing and maintaining, during the life of this Contract, public liability insurance for bodily injury and property damage liability, including, without limitation, coverage for explosion, blasting, collapse, and destruction of underground utilities (X.C.U.) and contingent liability, including products and contemplated operations and blanket contractual liability, and shall protect the Developer and the District and the engineer. The Developer or contractor shall have the District and engineer specifically added as additional insured in said policies, all at no cost to the District or engineer. The above insurance shall cover the District, engineer, Developer and subcontractors for claims and damages or any nature whatever, including but not limited to bodily injury, including wrongful death, as well as other claims for property damage which may arise from operations under this Contract whether such operations be by themselves or by any subcontractor or anyone directly or indirectly employed by either of them and the Developer agrees, in addition, to indemnify and save harmless the District and engineer, either or both, from all suits, claims, demands, judgments, and attorney's fees, expenses or losses occasioned by the performance of this Contract by himself, any subcontractor, or persons working directly or indirectly for him, or on account of or in consequence of any neglect in safeguarding the work or failure to conform with the safety standards for construction work adopted by the Safety Division of the Department of Labor and Industries of the State of Washington.

(b) The minimum amount of such insurance shall be as follows: Bodily injury liability insurance in an amount not less than \$1,000,000 for injuries, including accidental wrongful death, to any one person, and subject to the same limit for each person, in an amount not less than \$1,000,000 on account of any one occurrence, and property damage liability insurance in an amount not less than \$1,000,000 for each occurrence and \$2,000,000 aggregate.

(c) The Developer or contractor shall not cause any policy to be cancelled or permit it to lapse, and all policies shall include a clause to the effect that the policy or certificate shall not be subject to cancellation or to a reduction in the required limits of liability or amounts of insurance or any other material change until notice has been mailed to the District stating when, not less than thirty (30) days thereafter, such cancellation or reduction or change shall be effective.

(d) All certificates of insurance, authenticated by the proper officers of the insurer, shall state in particular those insured, the extent of the insurance, the location, character or extent of the work to be performed by such subcontractor. Such a determination of lesser coverage shall rest solely with the District.

(e) Copies of all insurance policies shall be kept on file at the District office.

VII. INDEMNIFICATION

The Developer will defend, indemnify and save the District, its officials, employees and agents and Engineers harmless from all claims and costs of defense thereof, including (by illustration but not limitation) attorney's fees, expert witness fees, and the cost of the services of engineering and other personnel whose time is reasonably devoted to the preparation and attendance of depositions, hearings, arbitration proceedings, settlement conferences and trials growing out of the demands of contractor, other property owners, or subcontractors, laborers, workmen, mechanics, suppliers, incurred in the performance or completion of the developer extension. The Developer shall, at the District's request, furnish satisfactory evidence that all obligations of the nature designated herein have been paid, discharged or waived.

VIII. PERFORMANCE BOND

(a) It is contemplated that the Developer will construct a portion of the developer extension on rights-of-way obtained by the District due to its franchise with King County, the City of Burien, the City of Normandy Park, or the City of SeaTac. It will be necessary for the Developer to abide by all King County, City of Burien, City of Normandy Park, or City of SeaTac regulations, as may apply, as well as to have the portion of the extension in this right-of-way comply with not only City or County regulations, but to District standards and regulations.

(b) The Developer shall furnish to the District a performance bond between the Developer/Contractor and the District in a minimum amount of \$10,000.00, or an amount equal to 150% of the total estimated cost of construction of the proposed improvements, whichever is greater. Said performance bond shall be conditioned upon the performance by the Developer of all undertakings, covenants, terms, conditions and agreements of the developer extension, and upon the prompt payment by the Developer to all persons supplying the labor and materials and the prosecution of the work provided by said developer extension and Contract. Such bond shall be executed by the Developer and a corporate bonding company licensed to transact such businesses in the State of Washington, and named on a current list of Surety Companies Acceptable on Federal Bonds as published in the Treasury Department's Circular No. 570. ED

(c) The expense of these bonds shall be borne by the Developer. If at any time a surety on any such bond is declared a bankrupt or loses its right to do business

in the State of Washington, or is removed from the list of "Surety Companies Acceptable on Federal Bonds," the Developer shall substitute an acceptable bond (or bonds) in such form and sum and signed by such other surety or sureties as may be satisfactory to the District. The premiums on such bonds shall be paid by the Developer. No further payment shall be deemed due nor shall be made until the new surety or sureties shall furnish an acceptable bond to the District.

IX. EASEMENTS

All required easements shall be obtained by the Developer at its sole cost and expense, and shall be delivered to the District after construction and prior to the acceptance by the District of the developer extension. The Developer shall provide all necessary easements at its sole cost regardless of changes in the Contract plans. Easements shall be drafted in conformity with the form set forth in the Developer's Developer Extension Manual and shall contain the provisions set forth in said form. A certified legal description of the easement shall be prepared by a licensed land surveyor or civil engineer. Each easement document shall include a surveyed sketch showing the location of the easement. All easements shall be at least fifteen (15) feet in width, centered on the sewer lateral. No other lines, mains, services, buildings or appurtenances shall encroach upon this 15-foot area and supervision during construction shall be the responsibility of the District. Violations shall be removed at no cost to the District.

X. PERMITS

(a) All the necessary permits from any governmental agency obtained by the District shall be at the Developer's expense. The Developer shall be provided with a copy of all such permits before construction commences. The Developer shall provide the District with necessary documents required to obtain the permits.

(b) For any permits obtained by the Developer, copies of the same shall be furnished to the District.

(c) Developer and/or contractor agrees to comply with all State, City and County regulations applicable to Developer and/or Contractor while construction is in progress in all right-of-ways.

XI. BILL OF SALE

Developer agrees to execute a Bill of Sale prepared by the District prior to the connection of the developer extension to the District's sewer system. Said Bill of Sale will provide for the transfer of title of the constructed extension from the Developer to the District and will further include the following:

(a) Developer is the lawful owner of said property and that it is free from all encumbrances.

(b) All bills for labor and material have been paid. Legible copies of all such bills shall be furnished to the District.

(c) The Developer shall have the right to transfer the same and that it will warrant and defend the same against lawful claims and demands of all persons for one (1) year after the date of acceptance of the Bill of Sale by the District.

(d) It will be recited that Developer grants the extension to the District for the consideration of incorporating the system in the overall sewer system of the District.

(e) Developer further warrants that for a period of one (1) year from the date of the connection that the sewer system will remain in working order and condition acceptable to the District and that Developer will repair or replace at its own expense any work or material that may prove to be defective during said one (1) year warranty.

XII. PAYBACK AGREEMENT EXECUTION AND RECORDING

Following receipt of the Bill of Sale, as heretofore described, the District agrees to execute and record a Payback Agreement pursuant to the terms of Chapter 57.22 RCW, Contracts for System Extensions, if and when appropriate. Said Payback Agreement will provide as follows:

(a) The parties agree to be bound pursuant to the terms of Chapter 57.22 RCW, Contracts for System Extensions.

(b) That Developer has constructed and installed the sewer line in the vicinity described in the Payback Agreement and portrayed by a map attached thereto.

(c) That said Bill of Sale has been attached to the Payback Agreement.

(d) That the line has been accepted by the District and that Developer will be supplied with sewer service at the rate established by the District for their class of service.

(e) That the Payback Agreement will continue for a period of fifteen (15) years from the date of the Agreement wherein the District will agree to collect latecomer fees as described in subparagraph (f) and remit such fees to the Developer and/or its assigns in accordance with this Agreement for the pro rata share of its cost of construction for said sewer line and improvements. After the expiration of fifteen (15) years, the District shall be under no further duty to the Developer to collect monies or to remit said monies for connection charges to the Developer.

(f) The owner of real estate who subsequently applies for service from the sewer facilities constructed pursuant to this Contract will be charged a fair pro rata

share of the cost of construction of this developer extension and shall conform to the District's latecomer resolutions.

(g) The District shall mail to the property owners the allocation of costs to be levied against the property which are payable upon their connection to the system, and any property owner shall have the right to a hearing with the Board of Commissioners within twenty (20) days after receipt of said notice for the purpose of requesting an adjustment of the allocation of the charge to the property.

(h) No person, firm or corporation shall use the sewer facilities or extensions thereof during the period of time prescribed in such Agreement without first paying to the District the full amount required by the provisions of the Payback Agreement. All amounts so received by the District shall be paid out by it under the terms of that Payback Agreement within sixty (60) days after the receipt thereof.

XIII. CONNECTION TO THE DISTRICT'S SYSTEM

The Developer shall notify the District in writing of its intent to connect its extension to the District's system. Said connection shall be supervised by District personnel. The District shall be given one week's notice of the Developer's intent to connect the developer extension with the District's sewer system and said connection shall be authorized and approved by the District through a resolution passed by the Board of Commissioners of the District authorizing the connection. The District, prior to the passage of the resolution, shall have received from the Developer the necessary permits, easements, Bill of Sale, and the certifications by the consultants for the District that the extension has been completed.

No connection shall be made without the express consent by the District as evidenced by resolution.

XIV. ACCEPTANCE BY DISTRICT OF DEVELOPER EXTENSION

For the one-year period following the passage of the District resolution authorizing the developer extension's connection to the sanitary sewer system, the Developer shall warrant the workmanship and materials and equipment furnished by the Developer, and shall be guaranteed by the Developer to remain in normal working order and condition, except where abused and neglected by the District, and the Developer shall repair or replace at its own expense any work or material that may prove to be defective during this guarantee period.

Between eleven (11) months and one (1) year from the date of passage of the resolution authorizing the District to connect the developer extension to the sanitary sewer system, the District shall reinspect the system to determine if the extension has complied to the warranty of the Developer and conforms to the District's standards and specifications. If said developer extension meets with the District's approval, then the District shall release the Performance and Maintenance Bond.

XV. ATTORNEY'S FEES

In the event this Contract is referred to or placed in the hands of the District's attorney for enforcement of any portion of this Contract, or if a lawsuit is instituted with respect to this Contract, and in the event the District is the prevailing party, the Developer agrees to pay the District's reasonable attorney fees, costs and expenses incurred by the District regarding said legal problem or lawsuit.

DATED this 7th day of April, 2023.

Elle Daneshnia 
Developer

Developer

DATED this _____ day of _____, 20____.

District

STATE OF WASHINGTON)

)ss.
COUNTY OF KING)

On this day personally appeared before me, a Notary Public in and for the State of Washington, duly commissioned and sworn, Ellic Darrish, known to me to be the individual(s) (Developer(s)) who acknowledged to me that he/she/they signed the foregoing Contract as his/her/their free and voluntary act and deed, for the uses and purposes therein set forth.

GIVEN under my hand and official seal this 7 day of April, 2023.

Kevin Reed Tongue
Notary Public in and for the State of Washington,
residing at King County. My commission
expires 4/30/2025.



STATE OF WASHINGTON)

)ss.
COUNTY OF KING)

On this day personally appeared before me, a Notary Public in and for the State of Washington, duly commissioned and sworn, _____, known to me to be the individual (a Commissioner representing the District who acknowledged to me that he/she signed the foregoing Contract as his/her free and voluntary act and deed, for the uses and purposes therein set forth.

GIVEN under my hand and official seal this ___ day of _____, 20__.

Notary Public in and for the State of Washington,
residing at _____. My commission
expires _____.

*** END OF SECTION ***

EXHIBIT A

Insert Project Cost Estimate

PORTION NW 1/4 AND NE 1/4 SECTION 07, TOWNSHIP 23 NORTH, RANGE 04 EAST, W.M. KING COUNTY WASHINGTON

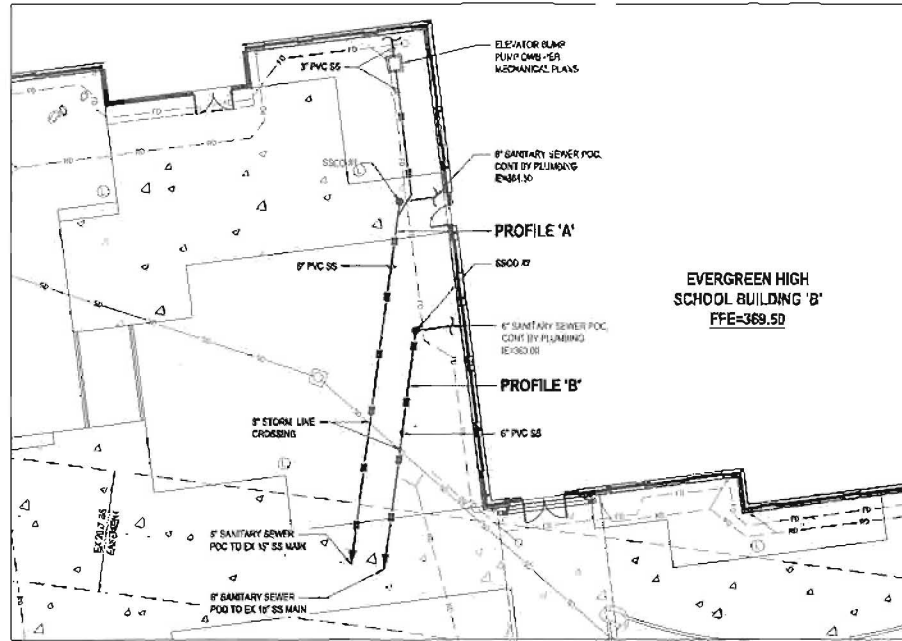

GENERAL SANITARY SEWER NOTES:

1. REFER TO EXISTING CE.M FOR GDA-F.A. NOTES, ABBREVIATIONS AND LEGENDS.
2. SANITARY SEWER SERVICES PERMITTED UNDER 100' PERMIT OR.
3. EXISTING UTILITIES SHOWN ON PROFILES ARE BASED ON BEST AVAILABLE INFORMATION AND MAY NOT BE ACCURATE. CONTRACTOR SHALL FIELD VERIFY PRIOR TO CONSTRUCTION AND NOTIFY THE ENGINEER OF ANY UTILITY CONFLICTS.
4. ADJUST THE RM ELEVATION OF ALL EXISTING SINKS TO OBTAIN WITHIN THE PROJECT BOUNDARY TO THE PROPOSED GRADE.

UTILITY LEGEND:

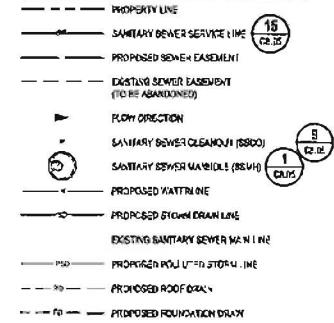

SANITARY SEWER PLAN 'A' and 'B'

SCALE: 1"=10'

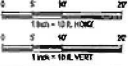
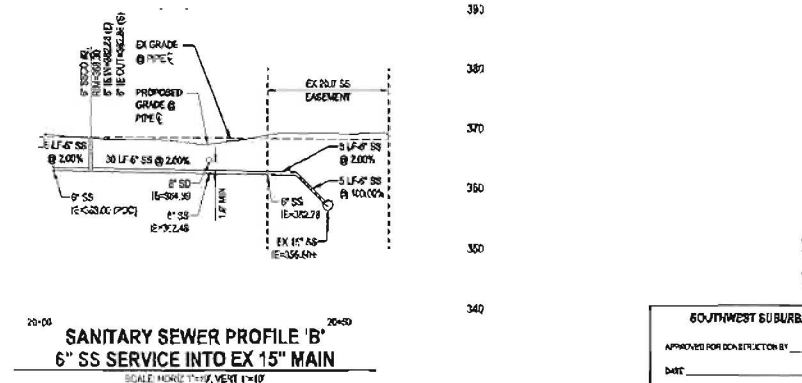
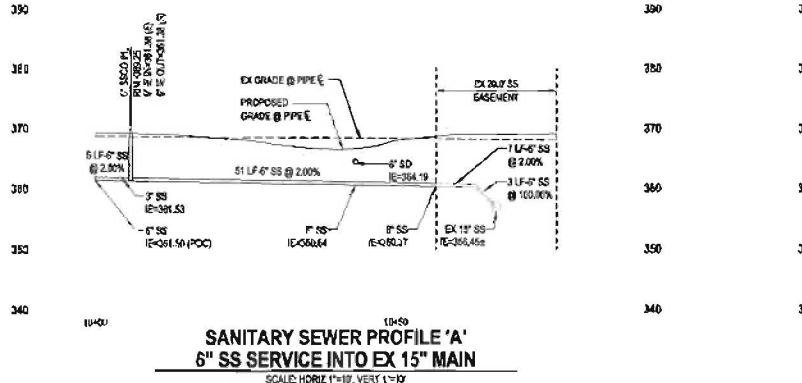

SOUTHWEST SUBURBAN SEWER DISTRICT

APPROVED FOR CONSTRUCTION BY _____

DATE _____

<p>NO. DATE BY CHL. APPR. REVIEW</p> <p>1 03/22/2023 MRM ATT TAE SOUTHWEST SUBURBAN SEWER DISTRICT SUBMITTAL</p>					<p>DRAWN BY: KWP</p> <p>CHECKED BY: NSM</p> <p>DATE: APRIL 20, 2023</p> <p>J O B No.: 2000051</p>	<p>DESIGNED BY: M.MATTHEIS</p> <p>APPROVED BY: MJE</p> <p>SCALE: AS SHOWN</p>	<p>3600 1st Avenue, Suite 1000 Seattle, WA 98101 206.462.3822 www.kpff.com</p>	<p>EVERGREEN HIGH SCHOOL / HIGHLINE PUBLIC SCHOOLS 830 SW 116TH STREET, SEATTLE, WA 98146</p> <p>SOUTHWEST SUBURBAN SEWER DISTRICT EVERGREEN HIGH SCHOOL DEVELOPER EXTENSION DE NO. 2023-X</p>	<p>SHEET: C8.02</p>
--	--	--	--	--	---	---	--	--	---------------------

PORTION NW 1/4 AND NE 1/4 SECTION 07, TOWNSHIP 23 NORTH, RANGE 04 EAST, W.M. KING COUNTY WASHINGTON

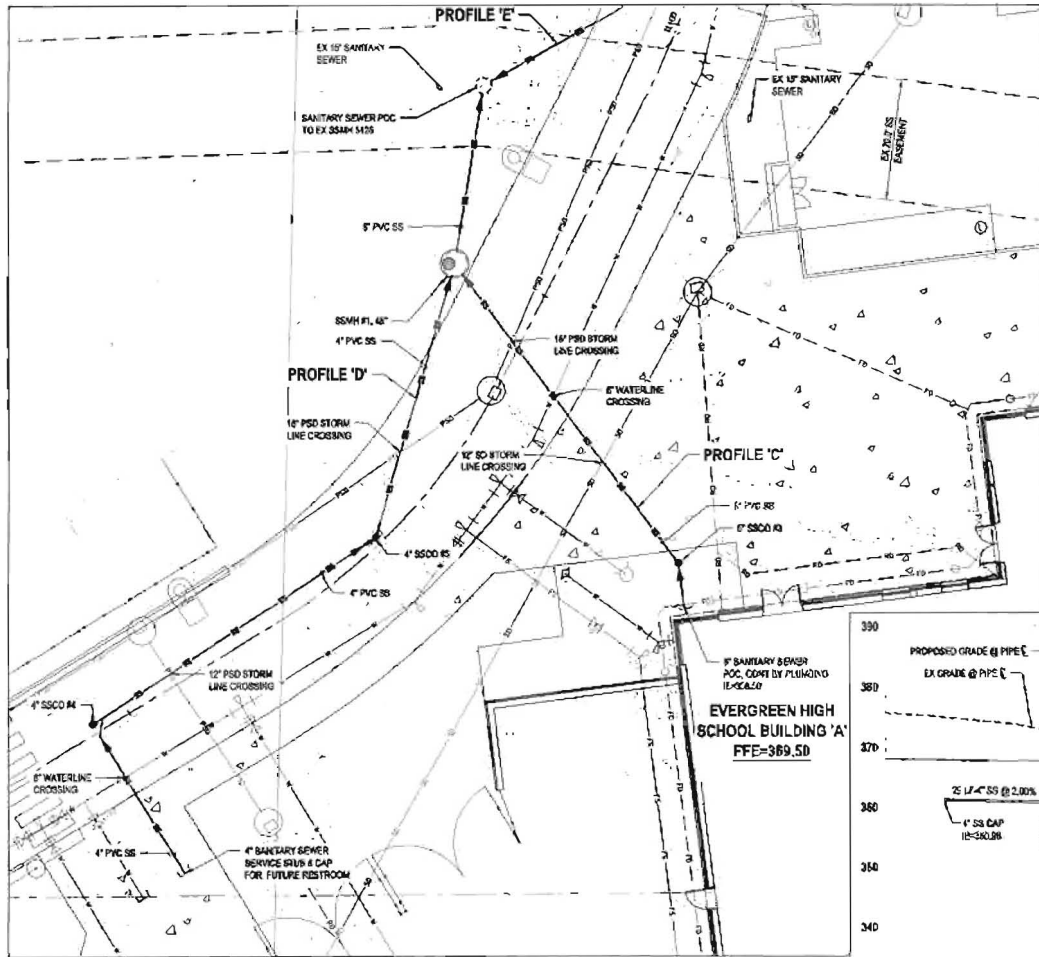

SANITARY SEWER PLAN 'C' and 'D'
SCALE: 1" = 10'

GENERAL SANITARY SEWER NOTES:

1. REFER TO THESE IS & OS FOR GENERAL ADOPTED ABBREVIATIONS AND SYMBOLS.
2. SANITARY SEWER SERVICES PERMITTED UNDER DEC PERMIT # 4.
3. EXISTING UTILITIES IN EXISTING OR PROPOSED ARE BASED ON BEST AVAILABLE INFORMATION AND MAY NOT BE ACCURATE. CONTRACTOR SHALL FIELD VERIFY PRIOR TO CONSTRUCTION AND NOTIFY THE ENGINEER OF ANY UTILITY CONFLICTS.
4. ADJUST THE RIM ELEVATION OF ALL EXISTING MANHOLES TO REMAIN WITHIN THE PROJECT BOUNDARY TO THE PROPOSED GRADE.

UTILITY LEGEND:

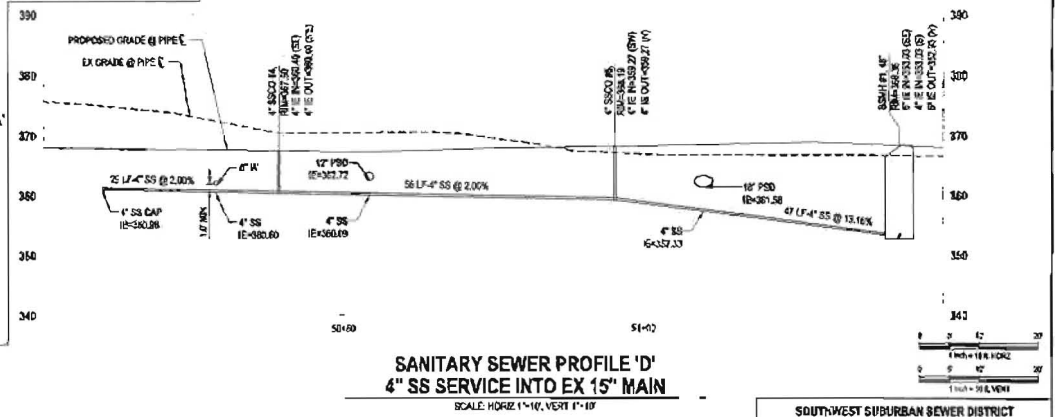
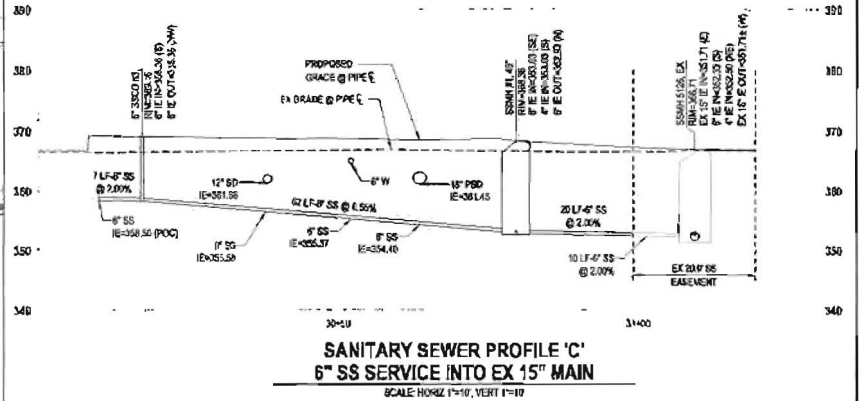
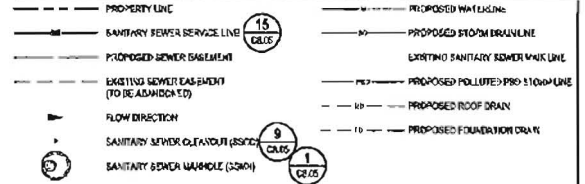

SOUTHWEST SUBURBAN SEWER DISTRICT
APPROVED FOR CONSTRUCTION BY _____
DATE _____

NO.	DATE	BY	CHKD	APPR	REVISION
1	03/02/2023	MMW	ATT	TJE	SOUTHWEST SUBURBAN SEWER DISTRICT SUBMITTAL

DESIGNED BY: MMS/MSR
APPROVED BY: TJE
DATE: APRIL 20, 2023
PROJECT NO.: 2020001
SCALE: AS SHOWN



EVERGREEN HIGH SCHOOL / HIGHLINE PUBLIC SCHOOLS
630 SW 116TH STREET, SEATTLE, WA 98146
SOUTHWEST SUBURBAN SEWER DISTRICT
EVERGREEN HIGH SCHOOL DEVELOPER EXTENSION
DE NO. 2023-X

SHEET
C8.03

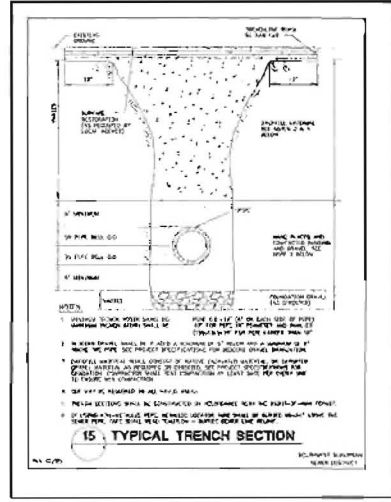
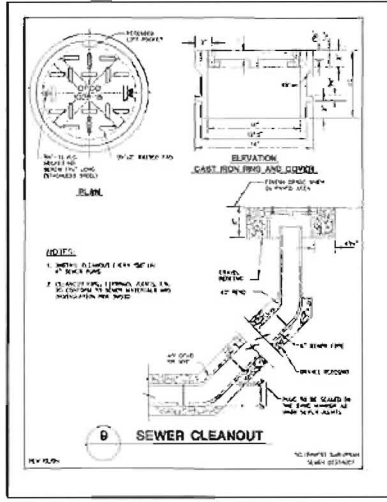
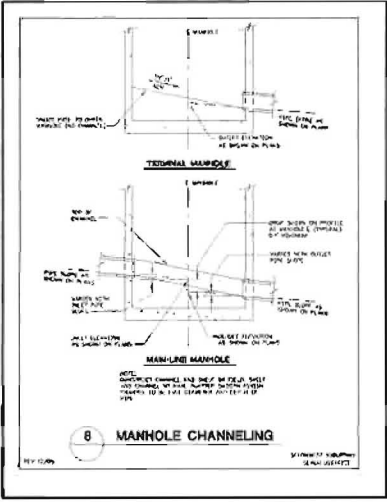
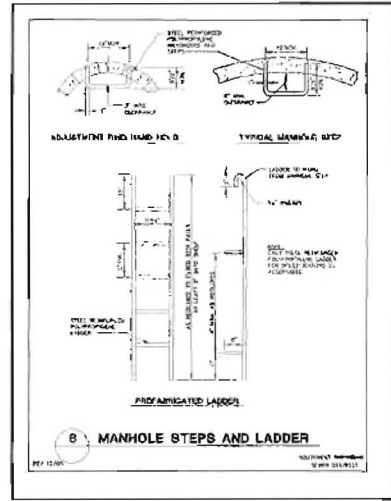
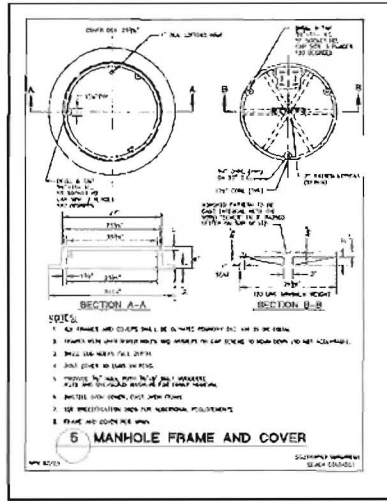
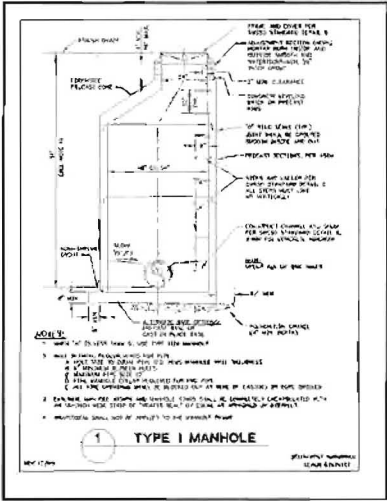

SOUTHWEST SUBURBAN SEWER DISTRICT
APPROVED FOR CONSTRUCTION BY _____
DATE _____

NO.	DATE	BY	CHG.	APPR.	REVISION
1	03/05/2023	MEM	ATY	TJE	SOUTHWEST SUBURBAN SEWER DISTRICT SUBMITTAL

DESIGNED BY: BSM
CHECKED BY: BSM
DATE: APRIL 03, 2023
I/O B No.: 200201

DESIGNED BY: BSM
APPROVED BY: TJE
SCALE: AS SHOWN

kpff
1800 5th Ave, Suite 1400
Seattle, WA 98101
206.422.2823
www.kpff.com

PRELIMINARY

EVERGREEN HIGH SCHOOL / HIGHLINE PUBLIC SCHOOLS
833 SW 116TH STREET, SEATTLE, WA 98148
SOUTHWEST SUBURBAN SEWER DISTRICT
EVERGREEN HIGH SCHOOL DEVELOPER EXTENSION
DE NO. 2023-X

SHEET
C8.05

King County iMap



King County EagleView Aerial Imagery, Inc.

The information included on this map has been compiled by King County staff from a variety of sources and is subject to change without notice. King County makes no representations or warranties, express or implied, as to accuracy, completeness, timeliness, or rights to the use of such information. This document is not intended for use as a survey product. King County shall not be liable for any general, special, indirect, incidental, or consequential damages including, but not limited to, lost revenues or lost profits resulting from the use or misuse of the information contained on this map. Any sale of this map or information on this map is prohibited except by written permission of King County.

Date: 7/26/2023

Notes:

